



Strategic Update:

- Partnership with Crédit Agricole
- ACE Project

03 December 2018

DISCLAIMER

This presentation has been prepared by Banco BPM ("Banco BPM"); for the purposes of this notice, "presentation" means this document, any oral presentation, any question and answer session and any written or oral material discussed following the distribution of this document.

The distribution of this presentation in other jurisdictions may be restricted by law or regulation. Accordingly, persons who come into possession of this document should inform themselves of, and observe, these restrictions. To the fullest extent permitted by applicable law, Banco BPM and its companies disclaim any responsibility or liability for the violation of such restrictions by any person.

This presentation does not constitute or form part of, and should not be construed as, any offer or invitation to subscribe for, underwrite or otherwise acquire, any securities of Banco BPM or any member of its group, nor should it or any part of it form the basis of, or be relied on in connection with, any contract to purchase or subscribe for any securities in Banco BPM or any member of its group, or any commitment whatsoever. This presentation and the information contained herein does not constitute an offer of securities in, the United States or to any U.S. person (as defined in Regulation S under the U.S. Securities Act of 1933 (the "Securities Act"), as amended), Canada, Australia, Japan or any other jurisdiction where such offer is unlawful.

The information contained in this presentation is for background purposes only and is subject to amendment, revision and updating. Certain statements in this presentation are forward-looking statements about Banco BPM. Forward-looking statements are statements that are not historical facts. These statements include financial projections and estimates and their underlying assumptions, statements regarding plans, objectives and expectations with respect to future operations, products and services, and statements regarding future performance. Forward-looking statements are generally identified by the words "expects", "anticipates", "believes", "intends", "estimates" and similar expressions. By their nature, forward-looking statements involve a number of risks, uncertainties and assumptions which could cause actual results or events to differ materially from those expressed or implied by the forward-looking statements.

Banco BPM does not undertake any obligation to update or revise any forward-looking statements, whether as a result of new information, future events or otherwise. You should not place undue reliance on forward-looking statements, which speak only as of the date of this presentation.

None of Banco BPM, its subsidiaries or any of their respective members, Directors, officers or employees nor any other person accepts any liability whatsoever (in negligence or otherwise) for any loss howsoever arising from any use of this presentation or otherwise arising in connection therewith.

By participating to this presentation and accepting a copy of it, you agree to be bound by the foregoing limitations regarding the information disclosed in this presentation.

This presentation includes both accounting data (based on financial accounts) and internal management data (which are also based on estimates).

EXECUTIVE SUMMARY

- **Binding MoU aimed at strengthening the partnership of Banco BPM and Crédit Agricole in the consumer credit sector** in Italy:

- Generating a significant capital uplift for Banco BPM (c.+80bps), whilst maintaining the existing shareholding in Agos (39%)
- Strengthening the partnership with Crédit Agricole, as well as Agos' leading position and market share in the sector

- **Massive derisking** via ACE Project for a total nominal amount of Bad Loans up to €7.8bn, in addition to a potential €0.8bn leasing portfolio

In the event that the optimisation would lead to a range between € 7.0 bn and € 7.8 bn

- the gross NPL ratio 30/09/2018 PF down to a range between ~ 11.3% / 10.6% **-4.6pp / -5.2 pp vs. 30/09/18**
- the net NPL ratio 30/09/2018 PF down to a range between ~ 6.9% / 6.6% **-1.6pp / -1.9 pp vs. 30/09/18**
- the gross Bad Loan ratio 30/09/2018 PF down to a range between ~ 3.7% / 3.0% **-5.0pp / -5.7 pp vs. 30/09/18**
- the net Bad Loan ratio 30/09/2018 PF down to a range between ~ 1.6% / 1.2% **-1.7pp / -2.1 pp vs. 30/09/18**

- **Healthy preservation of capital ratios:** thanks to the benefits of the agreement in consumer credit, the FL CET1 ratio pro-forma is set to remain in the area of 11%-11.5%¹, even in case of NPL disposal for an amount at the top of the range

Note:

1. Indicated on a pro-forma basis, with reference to the data as at 30/09/2018, including the estimated impact related to the strengthening of the Consumer Credit Business and to the ACE Project.

REORGANISATION OF THE CONSUMER CREDIT BUSINESS

Signed a binding MoU aimed at strengthening the partnership of Banco BPM and Crédit Agricole in the Consumer Credit sector in Italy

PROFAMILY

- Agos to acquire ProFamily “captive” business **for a total consideration of €310m**
- ProFamily, as part of Agos, will distribute its products through the entire branch network of Banco BPM Group, on an exclusive basis with a 15-year contract
- BBPM will keep 100% of former ProFamily “non captive”

AGOS

- **Agos will maintain its current shareholding structure: 61% CA and 39% Banco BPM**
- Definitive agreements will be signed between Banco BPM, CA and CACF including: Shareholders’ Agreement, Distribution Agreement and Funding Agreement, which will remain substantially unchanged other than in their duration (15 years)
- Banco BPM and CA have also agreed to explore the feasibility of an IPO of Agos over the next 2 years
- As part of the IPO, Banco BPM shall have the option (but no obligation) to reduce its current shareholding in Agos. Banco BPM has obtained from CA a put option on a 10% shareholding in Agos, at a price of €150m, exercisable in June 2021. Such guarantee, due to the implied reduction in the risk related to the capital invested, shall entail a consequent increase in Banco BPM’s CET1 ratio. This option is in any case unlikely to be exercised, given the wide gap between its strike price and the intrinsic value of Agos which is set to increase further as a result of the strengthening of the partnership.

Additional flexibility for both shareholders, while preserving their strong commitment for the future development of the company

- **Generating a significant capital uplift for Banco BPM (c.+80bps¹)**, whilst maintaining the existing shareholding in Agos
- Strengthening the partnership with CA, as well as Agos’ leading position and market share in the sector

Note:

1. Pro-forma impact expected from the completion of the agreement calculated, all other conditions being equal, assuming as reference basis the CET1 ratio fully loaded as at 30 of September 2018 (11.2% PF).

STRUCTURE OF THE TRANSACTION IN CONSUMER CREDIT

KEY STEPS OF THE POTENTIAL STRUCTURE POST TRANSACTION

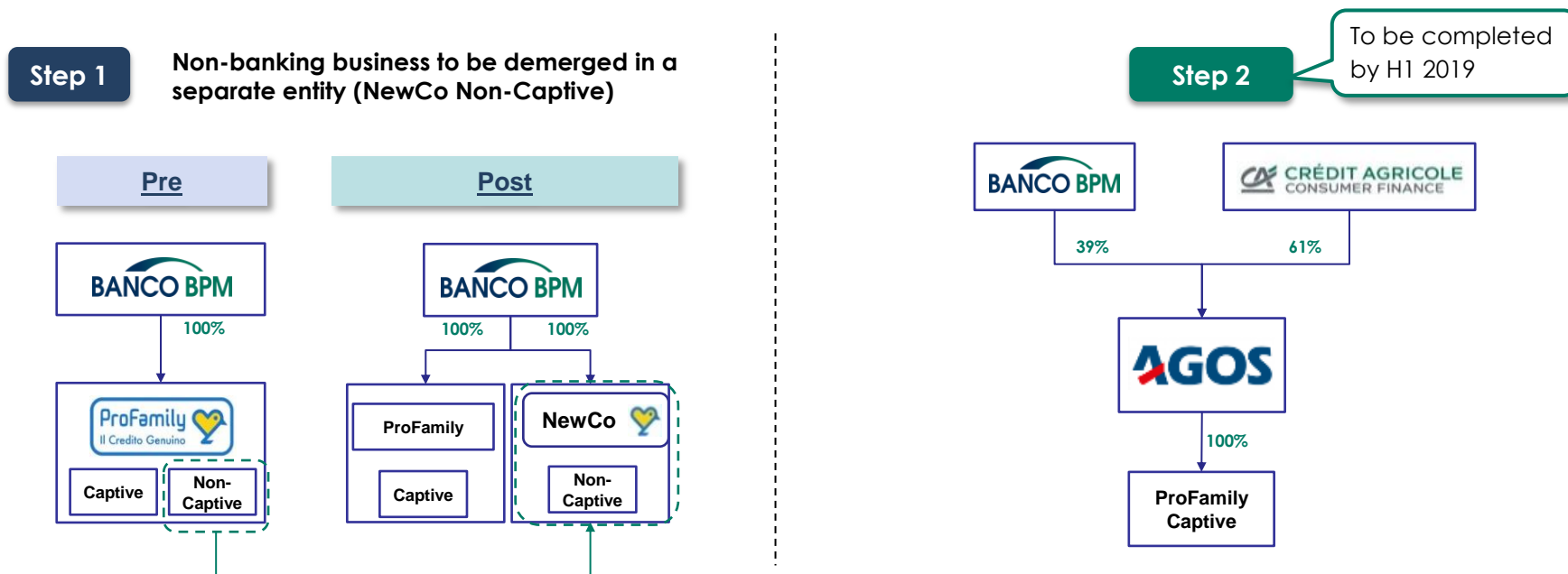

It is reminded that, as part of a possible IPO of Agos to be explored with CA, Banco BPM would have the option to reduce its stake in Agos by 10%, exercisable in June 2021

UPDATE ON ACE PROJECT

1 NPL Portfolio

Up to €7.8bn Nominal Book Value



- **Minimum required to complete 2018-20 plan submitted to ECB:** €3.5bn disposal
- **Current base case scenario:** acceleration of the derisking plan via larger disposal

Potential platform set-up and sale dependent upon several factors

2 NPL Recovery B.U.

Business Unit dedicated to loan recovery activities



Definition of the Business Unit Perimeter and subscription of a servicing agreement



Offers

Towards closing

STATUS

- **Banco BPM received offers** from three consortia – Credito Fondiario-Eliot, doBank-Fortress-Ilimity and Prelios-CRC – for the full perimeter of credit bad loans earmarked for disposal by the bank as well as for sub-perimeters
- Offers have been provided for **both GACS and non-GACS financing structures**, in order for Banco BPM to **maintain flexibility on the potential financing structure** of the transaction, maximising the outcome for the bank
- Bidders also submitted offers for the **NPL Recovery Business Unit**

NEXT STEPS

- Following the board of 29-Nov, **Banco BPM will continue the negotiation with the three consortia** in order to sign a framework agreement as soon as possible
- Final size of the portfolio ranging between **€7.0bn - €7.8bn of nominal book value** equivalent to a **gross balance sheet exposure of €6.0bn and €6.8bn**, respectively
- Possible **partnership for the NPL Recovery Business Unit** and subscription of a **long-term servicing agreement**
- Prosecution of **DD on leasing portfolio** aimed to **obtain final offers**

NPL DYNAMICS AT A GLANCE: EXCELLENT FURTHER DERISKING TO COME VIA ACE PROJECT

€ bn – Total NPLs, gross book value

NPL Dynamics since YE 2015 – including ACE

-€15.5/16.3bn disposals
 -€8.5bn cancellations, recoveries, cure and other³
 +€6.0bn inflows from performing to Bad Loans and UTP

NPL Stock reduction since YE 2015: -€18.0/18.8bn

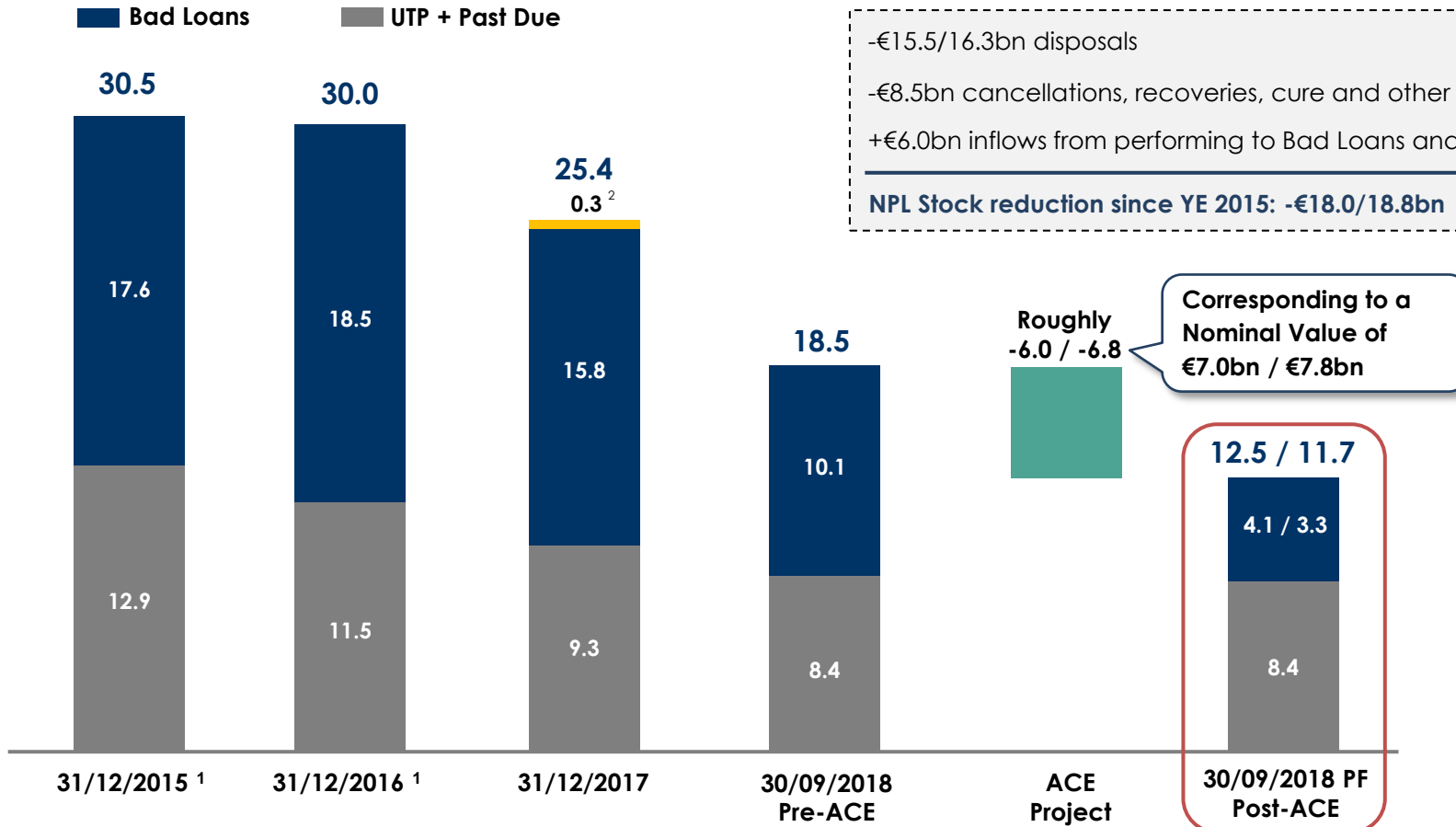

Internal management analysis

Notes:

1. Accounting gross book value, including restatement for managerial purposes (inclusion of a portion of write-offs, in coherence with the restatement done in 2017).
2. Subject to IFRS 9 reclassification.
3. Other includes net change in Past Due and IFRS 9 reclassification impact.

SHARP DROP IN NPL RATIOS

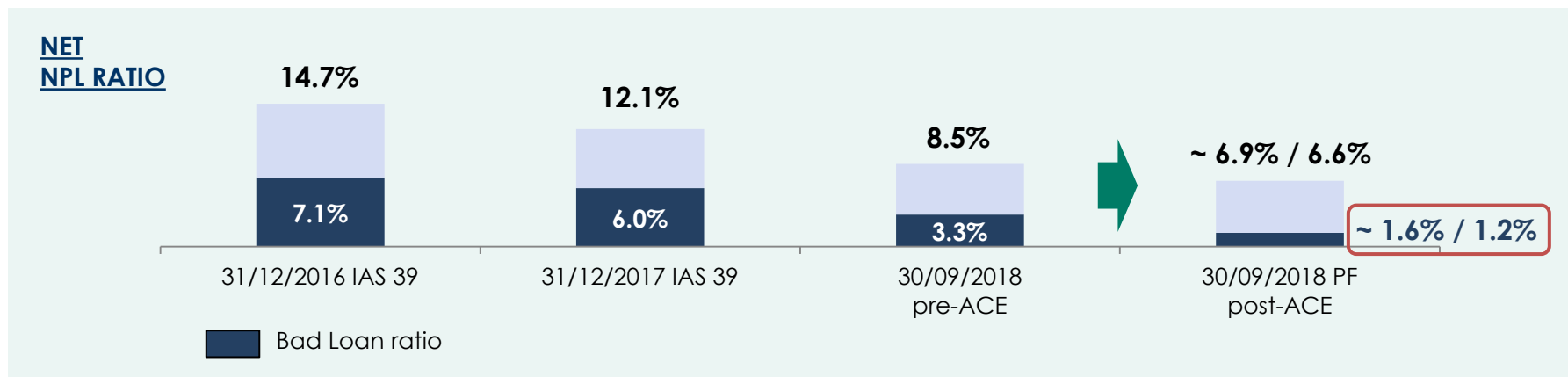
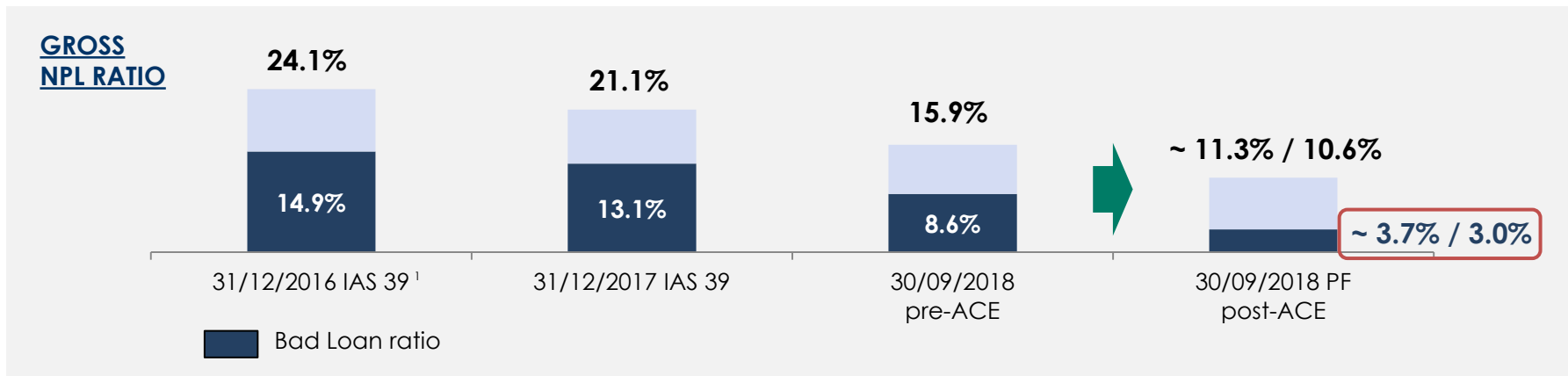

Trend since YE 2016 and YTD also impacted by IFRS 9 FTA.

Note:

1. Data restated excluding from the Nominal amount only the write-offs which remained off-balance sheet at the beginning of 2017.

CONSIDERATIONS ON THE RESIDUAL BAD LOAN PORTFOLIO

Assuming disposal of full ACE portfolio (€7.8bn Nominal Book Value)

Analysis of the residual portfolio

Key data on residual Bad Loan portfolio	Accounting GBV (€bn)	Accounting coverage	Share of secured
Total	3.3	60.6%	72.7%

<i>of which: Leasing¹</i>	1.7	58.1%	85.9%
------------------------------------------	-----	-------	-------

<i>of which: Other bad loans¹</i>	1.6	63.2	58.6%
--------------------------------------------------	-----	------	-------

Focus on the Leasing portfolio¹

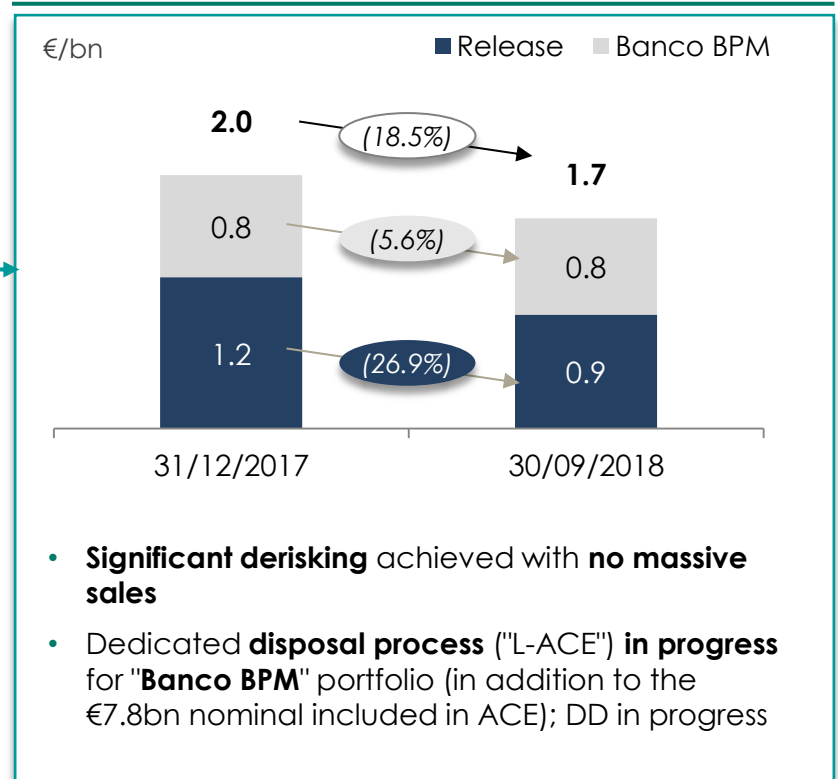

Note:

1. Managerial Data.

SOUND CAPITAL POSITION CONFIRMED

Solid buffer vs. the 2018 SREP requirement to be confirmed. In fact, the benefits of the agreement in Consumer Credit are anyhow set to allow the bank to fully face the overall effects on capital related to the ACE transaction, even in case of NPL disposal for an amount at the top of the range

CET 1 ratio Phased-in

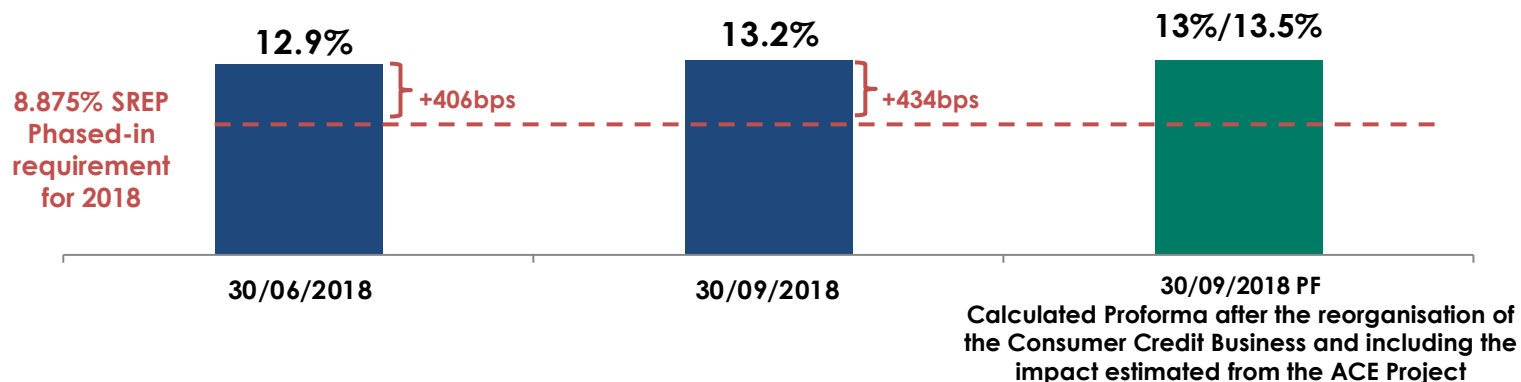

CET 1 ratio Fully Loaded

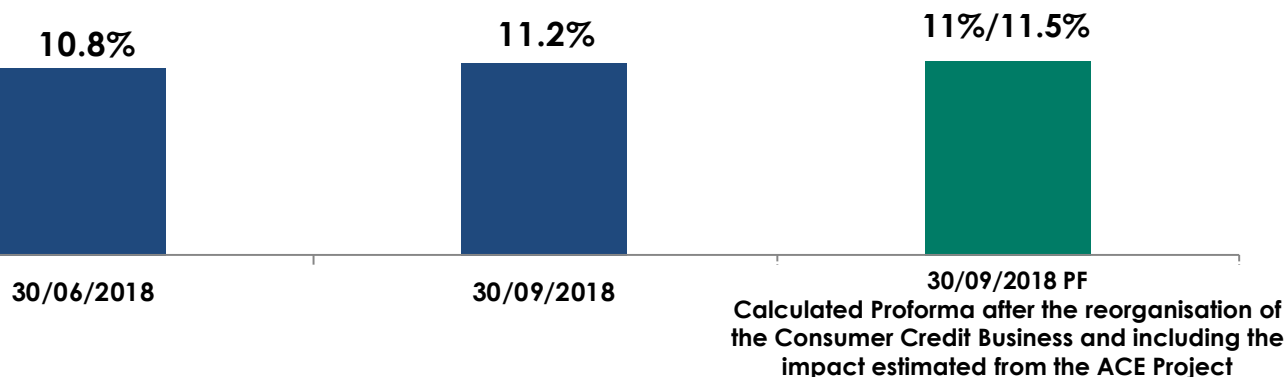

CONTACTS FOR INVESTORS AND FINANCIAL ANALYSTS

INVESTOR RELATIONS



Roberto Peronaglio	+39-02-7700.2574
Tom Lucassen	+39-045-867.5537
Arne Riscassi	+39-02-7700.2008
Silvia Leoni	+39-045-867.5613
Andrea Agosti	+39-02-7700.7848

Registered Offices: Piazza Meda 4, I-20121 Milan, Italy
Corporate Offices: Piazza Nogara 2, I-37121 Verona, Italy

investor.relations@bancobpm.it
www.bancobpm.it (IR Section)

